

64 3 9823454

3604
#178



LAZER-ALIGN

REPORT FORM

Truck Alignment Services Ltd
PO Box 16 345, Christchurch 8042
Ph: (03) 982 3453 Fax: (03) 349 7005

REG NO 15715 MAKE/MODEL Wade tanker KM 214000 BSK
OWNER Miller's Engineering #1952 DATE 18/7

130
126

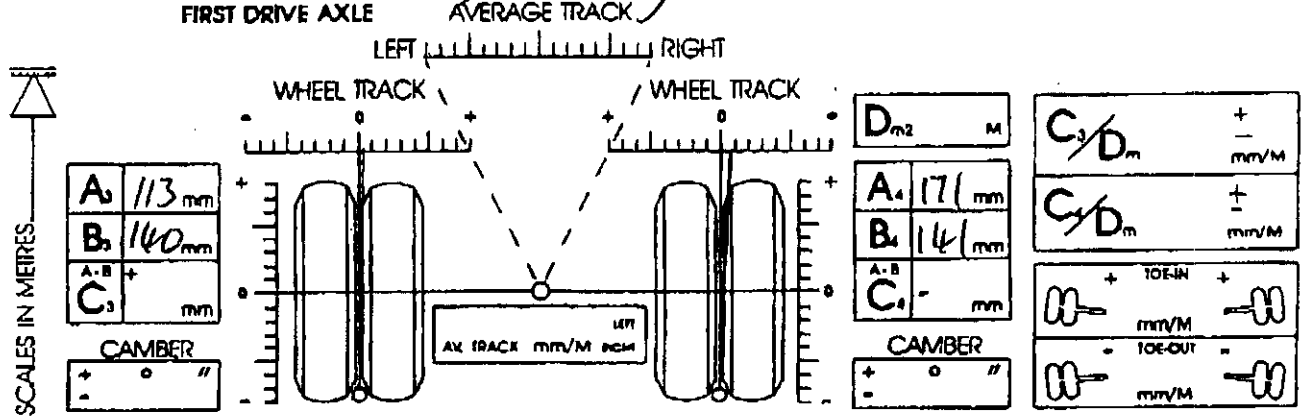

153
155

140
134

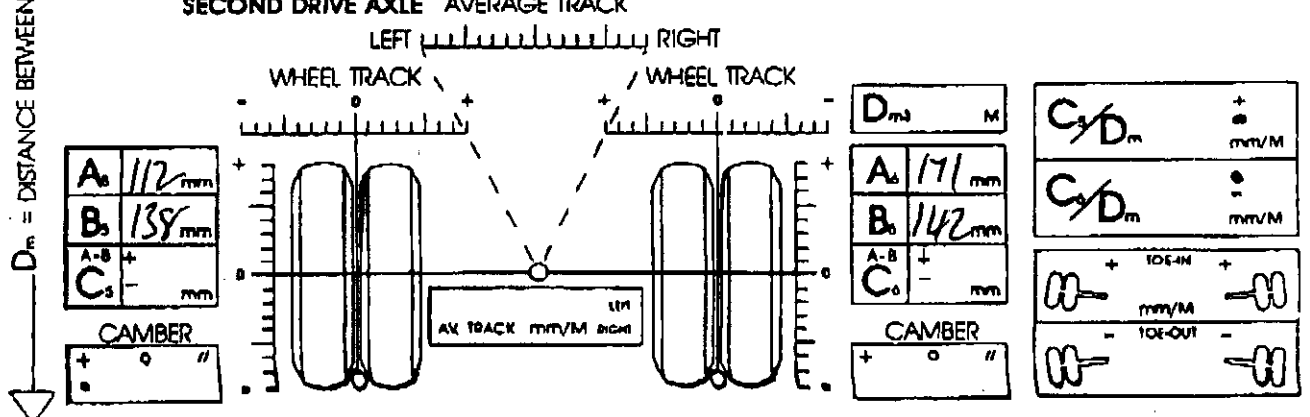

147
148

AVERAGE OUT OF SQUARE mm/M MAX. OUT OF PARALLEL mm/M

145
150
EOA

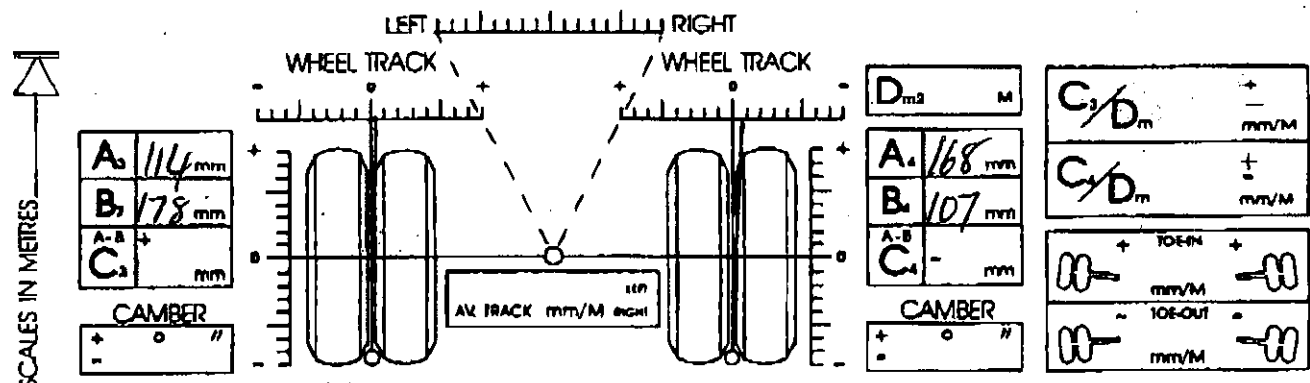

146
132
EOA

End of Adjustment

146
139

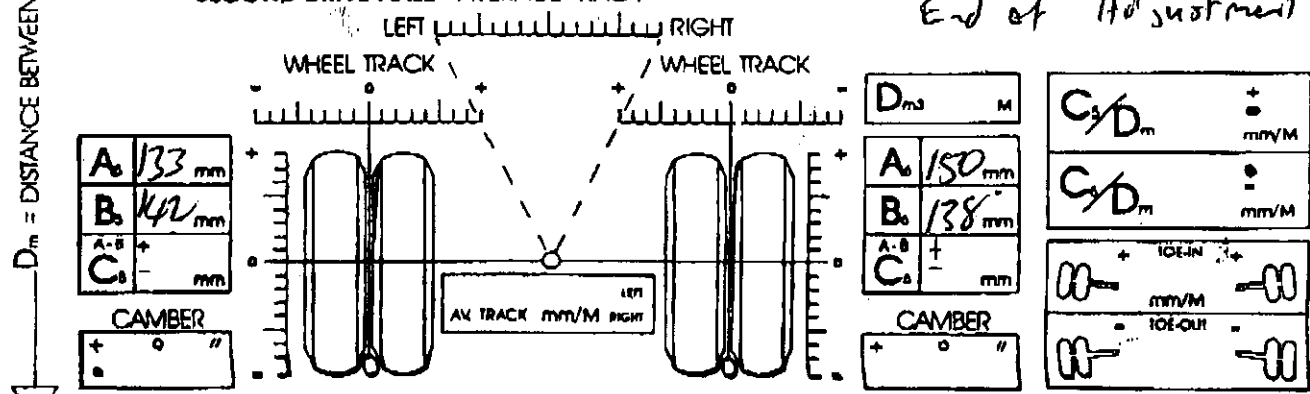

138
142

0 100 200 300 B = REAR SCALE = B 300 200 100 0

AVERAGE OUT OF SQUARE mm/M MAX. OUT OF PARALLEL mm/M