



an **ArvinMeritor** brand

Meritor Warranty Terms and Conditions

As of 1st March 2002

ArvinMeritorTM



an ArvinMeritor brand

Warranty Terms and Conditions

Meritor Trailer Products Warranty Terms

Meritor HVS Limited (“Meritor”) warrants to the owner (“Owner”) that the Meritor components listed in this publication, which have been installed by an Original Equipment Manufacturer (“OEM”) as original equipment in vehicles licensed for on-highway use, will be free from defects in material and workmanship as described below. The duration of warranty cover for each component and assembly is given below. This warranty covers failures occurring from the date that the trailer entered service, providing this date does not exceed six months from the original date of purchase ex Meritor. Duration of coverage and mileage limitations vary by component and application and are detailed within this publication.

All components are warranted for either parts and labour costs or in certain cases parts only as specified by the duration and extent of coverage limitations detailed within this publication. Allowances for labour costs associated with the repair or replacement of the subject component will only be paid at a rate approved in writing by Meritor before any such work is undertaken.

Genuine Meritor replacement parts (whether new, used or re-manufactured) installed under this warranty are warranted only for the remainder of the original period of time or mileage of the original warranty agreement.

WARRANTY COVERAGE IS DEPENDENT ON ADHERENCE TO APPROVED MERITOR INSPECTION INTERVALS, SERVICE INTERVALS AND SERVICE REPLACEMENT PROCEDURES OF COMPONENTS OR ASSEMBLIES AS SPECIFIED IN THE APPLICABLE MERITOR PUBLISHED SERVICE LITERATURE.

Warranty coverage for certain components requires the use of specific lubricants. For information about lubrication and maintenance intervals refer to Meritor published service literature.

For trailer applications which fall outside the Meritor standard usage specification, Meritor authorisation must be obtained at the point of purchase. Any change in trailer application that may affect the service life of the component parts must be notified to and approved by Meritor. Failure to do so may invalidate warranty cover.

This warranty does not cover normal wear and tear; nor does it cover a component that fails, malfunctions, or is damaged as a result of (I) improper installation, adjustment, repair or modification (including the use of unauthorised attachments or changes or modification in the vehicle’s configuration usage, or vocation from that which was originally approved by Meritor); (II) accident, natural disaster, abuse or improper use (including loading beyond the specified maximum rated carrying capacity); or (III) improper or insufficient maintenance (including deviation from approved lubricants, change intervals or lubrication quantities).

This warranty does not cover any component or assembly that is not manufactured or sold or marketed by Meritor.

This warranty does not cover the costs of any repairs, replacements or adjustments to a covered component:

- associated with noise;
- resulting from the use or installation of non-genuine Meritor components or material;
- due to vibration resulting from improper operation or misapplication of associated trailer components.

THIS WARRANTY IS EXPRESSLY IN LIEU OF ALL OTHER WARRANTIES OR CONDITIONS, EXPRESSED, IMPLIED OR STATUTORY, INCLUDING ANY IMPLIED WARRANTY OF MERCHANTABILITY OR FITNESS FOR PARTICULAR PURPOSE.

The exclusive remedy under this warranty shall be the repair or replacement of the defective component at Meritor’s option. Meritor reserves the right to require that all applicable failed materials are available and/or returned to Meritor for review and evaluation.

In no event shall Meritor be liable for special, incidental, indirect, or consequential damages of any kind or under any legal theory, including, but not limited to, towing, downtime, lost productivity, cargo damage, taxes, or any other losses or costs resulting from a defective covered component.

This is the entire agreement between Meritor and the Owner about warranty and no Meritor employee or dealer is authorised to make any additional warranty on behalf of Meritor. This agreement allocates the responsibilities for component failure between Meritor and the Owner.

To assist in warranty claims and service breakdowns it is advisable to register your trailers at point of purchase using the official Meritor registration card. Likewise changes of ownership should be advised to Meritor for immediate change to the registration documents. There is no charge to the Owner for this Warranty. This Warranty may also be transferred to subsequent Owners providing any change in trailer application is notified to and approved by Meritor as detailed above.

If the Owner discovers within the applicable coverage period a defect in material or workmanship, the Owner must promptly give notice to either Meritor or the dealer from which the vehicle was purchased. To obtain service, the vehicle must be taken to any participating new trailer dealer or authorised Meritor service location.

The dealer will inspect the vehicle and contact Meritor for an evaluation of the claim. When authorised by Meritor, the dealer will repair or replace during the term of this warranty any defective Meritor component covered by this warranty.

Meritor reserves the right to alter, amend or change specification of any product without prior notification.

Hub Warranty LMC and TAC Series Axles

The following duration and extent of warranty cover is applicable whenever a Meritor LMC or TAC Series axle is purchased together with a Meritor Flexair suspension as an assembly ex Meritor.

A 7 year or 1,000,000 km, whichever comes first, warranty period, parts only, is offered for the following components and assemblies:

- Hub structure, LMC/TAC comprising the hub and bearing assembly including wheel studs, but not including auxiliary seal, hub cap, hub cap gasket and fixings and ABS components (where fitted).
- **Note 1:** The appropriate MERITOR recommended anti-fretting compound must be applied to the spindle bearing journal prior to re-mounting the hub assembly on every occasion. Failure to do so may invalidate the warranty cover.
- **Note 2:** Under NO circumstances should any attempt be made to remove:
 - The circular spring bearing retaining clip from the hub.
 - The sealed bearing assembly from the hub.
 - Either of the two oil seals integral to the bearing unit from the bearing.
 - The spring clip between the two halves of the inner bearing cone.

This will damage the hub assembly and invalidate the hub warranty.

The duration and extent of warranty cover for all other features of the LMC/TAC axle remains unchanged from the standard LM/TA or LM DX195/TA Duco warranty terms as shown below:

Warranty LM, TA and TM Series Axles with Meritor Suspension Fitted

The following duration and extent of warranty cover is applicable whenever a Meritor LM, TA or TM Series axle is purchased together with a Meritor Flexair suspension as an assembly ex Meritor ordered as of 1st October 1999.

A 5 year or 500,000 km, whichever comes first, warranty period, is offered for the following components and assemblies:

- Complete beam weld assembly as supplied from Meritor, comprising finished axle beam and all welded bracketry (including Flexair spring seats).
- **Note 1:** In some special cases it may be possible for a third party to weld certain bracketry to the axle beam providing prior written approval has been obtained from Meritor and Meritor welding procedures are adhered to at all times. Failure to do so will invalidate warranty cover.
- **Note 2:** This warranty cover will not apply where makes of suspension other than Meritor are used in conjunction with Meritor LM series axles or in other certain special applications. In such cases the higher rated LM/9300 beam weld assembly must be used and the warranty period of the welded beam assembly will be reduced as described below.

A 3 year or 300,000 km, whichever comes first, warranty period, is offered for the following components and assemblies:

- Axle end fixings in their entirety (Effective for product sold from 1st October 1999).
- Hub structure, LM/TA/TM comprising the hub and bearing assemblies including wheel studs, but not including auxiliary seal, hub cap, hub cap gasket and fixings and ABS components (where fitted). (Effective for product sold from 1st October 1999).

- **Note 1:** The appropriate Meritor recommended anti-fretting compound must be applied to the spindle bearing journal prior to re-mounting the hub assembly on every occasion. Failure to do so may invalidate the warranty cover.

- Brake drums are covered for mechanical failure and not for wear out provided that approved Meritor brake linings are used.

A 2 year or 200,000 km, whichever comes first, warranty period, is offered for the following components and assemblies effective for product sold from 1st October 1999:

- Brake Rotors are covered for mechanical failure and not wear out.
- Camshaft, camshaft bearings, cam rollers, brake anchor pins.
- Caliper assemblies
- **Note 1:** Excludes damage due to off-road usage.

A 1 year or 100,000 km, or up to first brake re-line, whichever comes first, warranty period, is offered for the following components and assemblies:

- Hub cap and screws.
- Dust covers and screws.
- Hub cap gasket is covered for mechanical failure only and not for wear out.
- ABS sensor, bracket and pole wheel.
- Brake shoe or pad assemblies. Brake linings are covered for mechanical failure only and not for wear out.
- Brake retaining springs and brake return springs.
- All oil and grease seals are covered for mechanical failure only and not for wear out.
- All other ancillary components not previously listed e.g. brake roller retaining clip, blanking grommets etc. are covered for mechanical failure only and not for wear out.

Associated Labour Costs:

- Labour costs can only be claimed at an agreed rate with the Meritor Service Department prior to work commencing.

Warranty LM, TA and TM Series Axles without Meritor Suspension Fitted

The following duration and extent of warranty cover is applicable whenever a Meritor axle is used in conjunction with a make of suspension other than Meritor or whenever a Meritor axle is purchased without a Meritor Flexair suspension as an assembly ex Meritor or in other certain special applications specified by Meritor at the time of purchase.

- All components and assemblies previously listed with a 5 year / 500,000 km warranty period are reduced to a **3 year or 300,000 km, whichever comes first, warranty period.**
- All components and assemblies previously listed with a 3 year / 300,000 km warranty period are reduced to a **1 year or 100,000 km, or up to first brake reline, whichever comes first, warranty period.**
- All components and assemblies previously listed with a 2 year / 200,000 km warranty period remain at **2 years or 200,000 km, whichever comes first, warranty period.**
- All components and assemblies listed above with a 1 year / 100,000 km warranty period remain at **1 year or 100,000 km, or up to first brake reline, whichever comes first, warranty period.**
- All labour costs previously covered for the first 3 years of warranty are reduced to the **first 2 years or for the total duration of the warranty of the associated component whichever is the shortest.**

Quick Warranty Reference Chart

LMC/TAC, LM/TA and TM Hubs – Refer to warranty statement for full terms and conditions of cover.

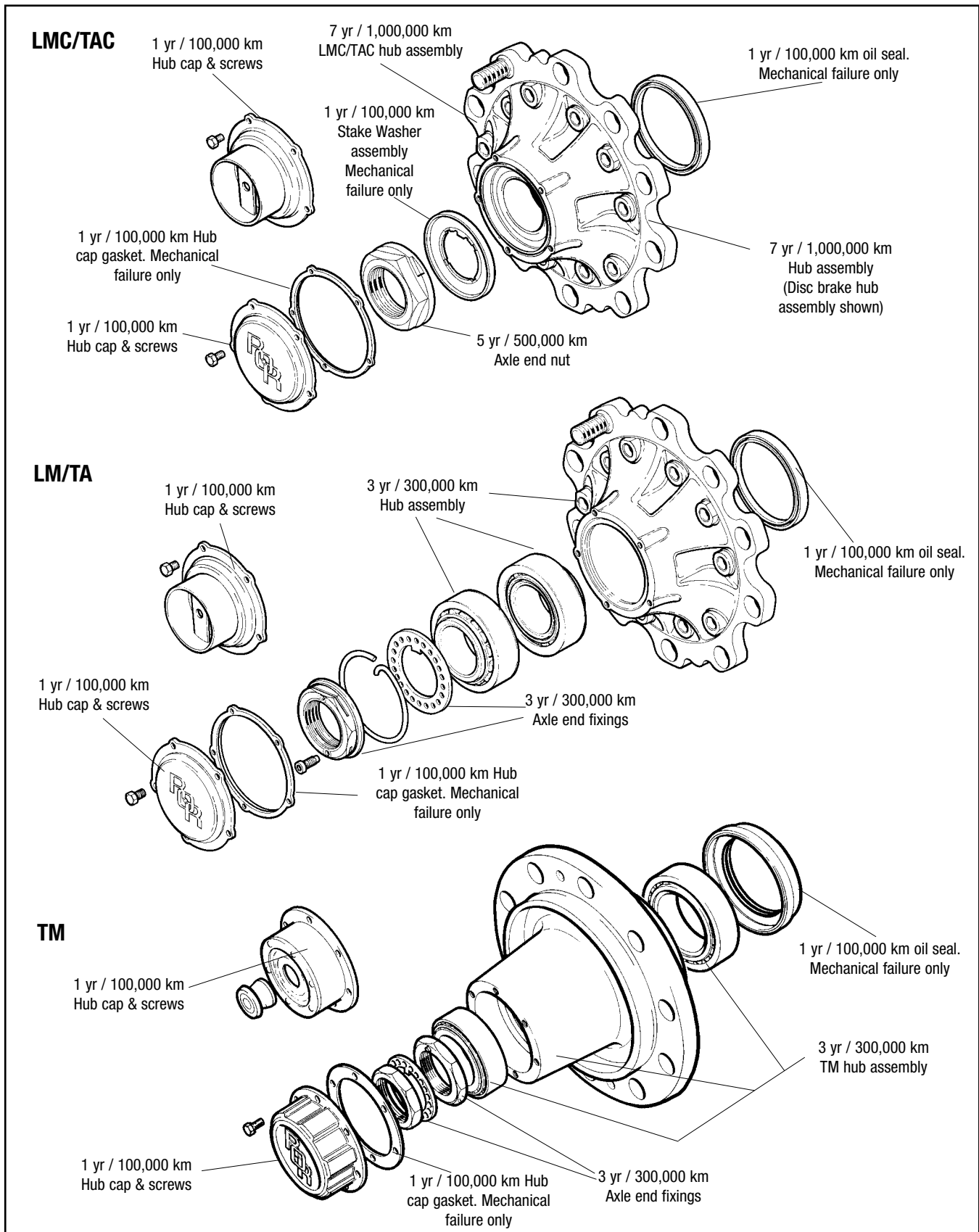

Any component not referred to above is covered by a 1 yr / 100,000 km warranty for mechanical failure only.

Quick Warranty Reference Chart

Disc Brakes for LM, TA or TM Axles – Refer to warranty statement for full terms and conditions of cover.

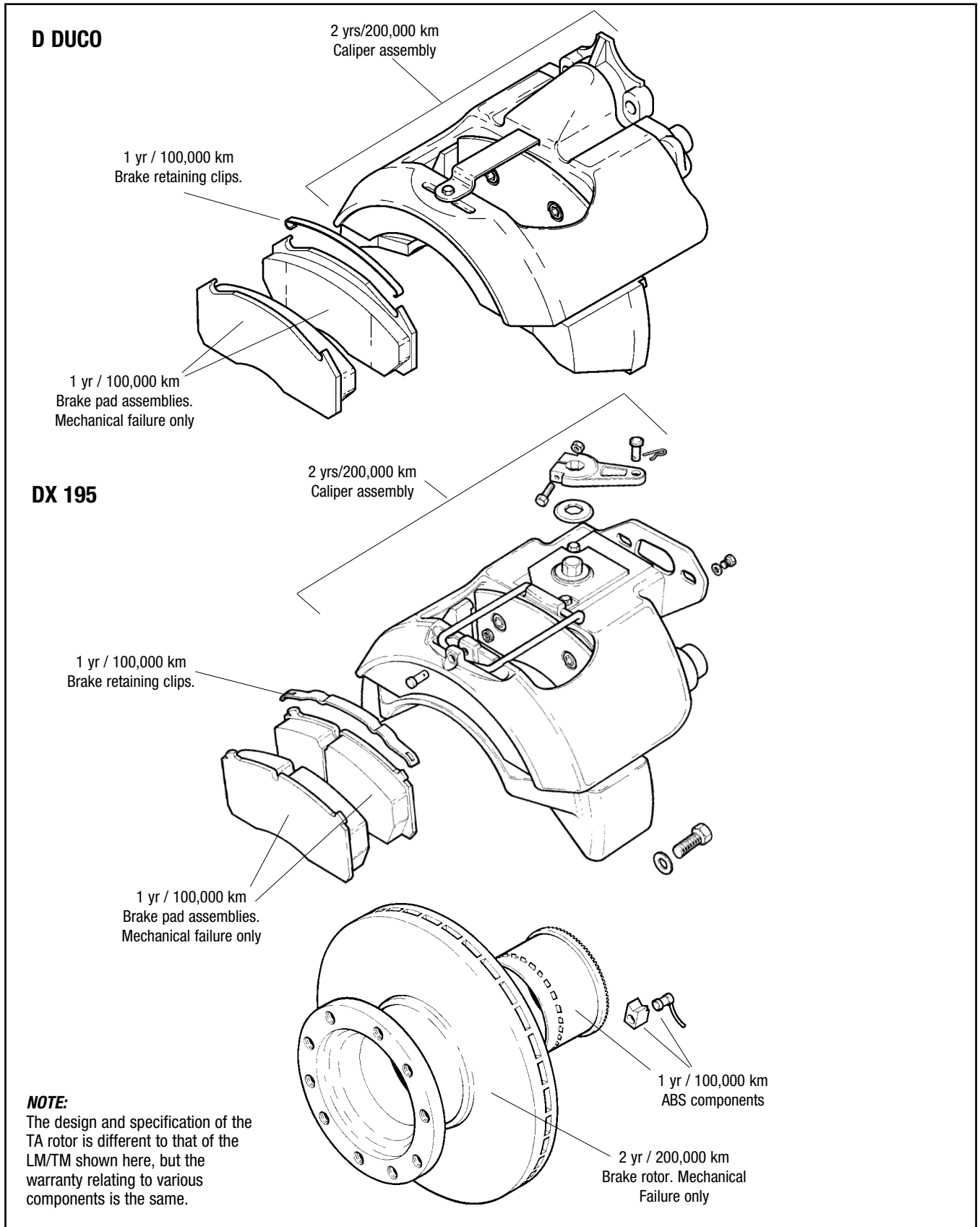

Any component not referred to above is covered by a 1 yr / 100,000 km warranty for mechanical failure only.



an ArvinMeritor brand

Quick Warranty Reference Chart

LM Axle shown – Same conditions for TA, TM Axle – Refer to warranty statement for full terms and conditions of cover.

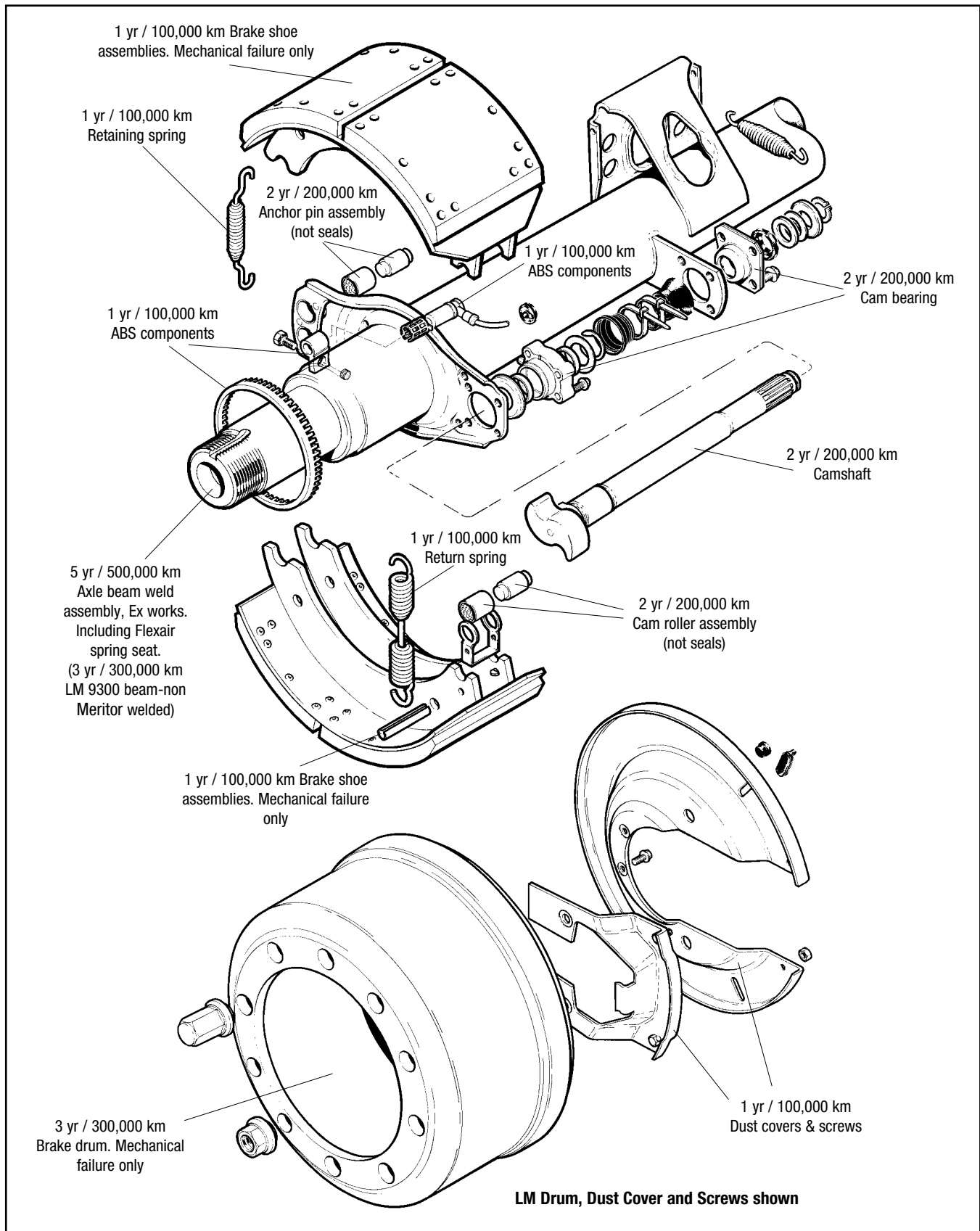

Any component not referred to above is covered by a 1 yr / 100,000 km warranty for mechanical failure only.



Meritor H.V.S. Suspension Warranty

1. MECHANICAL, FLEXAIR AND INDAIR SUSPENSIONS 24 MONTHS PARTS AND LABOUR

2. FLEXAIR AND FLEXLITE UNITS ASSEMBLED WITH AXLE BY MERITOR H.V.S. 36 MONTHS PARTS AND LABOUR

OTHER ANCILLARY EQUIPMENT SUPPLIED BY MERITOR

All MERITOR ancillary products such as LevelRide II, Spring Brakes, Slack Adjusters, Landing Legs, Fifth Wheels etc, are manufactured to the highest quality and backed by a two year parts only warranty.

Unless otherwise stated, Aftermarket components are warranted for 1 year, parts only, mechanical failure only.

Warranty Procedure

Should any MERITOR equipment fitted to your trailer become unserviceable within the warranty period, contact the trailer manufacturer or MERITOR Service Department who will advise on the appropriate action.

A comprehensive network of original parts distributors and service stations operate throughout Europe; this is supported internationally with agents strategically placed around the world.

MERITOR H.V.S. reserve the right to make changes in specifications shown herein or add improvements at any time without notice or obligation.

PARTS SHOWN ARE MADE FROM DRAWINGS IN WHICH COPYRIGHT SUBSISTS. THE MAKING OF COPIES OF ANY OF THESE PARTS IS PROHIBITED.

Patents and applications of MERITOR H.V.S. Ltd that are specifically relevant to air suspension systems:

Indair ride height adjustment, GB Patent No. 2165500. **Shock absorbers as restraints**, GB Patent No. 2165501. **Indair suspension**, GB Patent No. 2165195, CA Patent No. 1232302, DE Patent No. 3437393, NZ Patent No. 209838, US Patent No. 4593930. **Deflation of air suspension**, GB Patent No. 2184405. **Compact Indair**, GB Patent No. 2194761. **Load distribution on air suspended vehicles**, GB Patent No. 2239222, EPO (BE, DE, DK, ES, FR, IT, NL) appn. 90314050, AU Patent No. 646005, IE appn. 4530/90, NZ appn. 236519, PT appn. 96354, ZA Patent No. 90/10241. **Suspensions for vehicles (long stroke)**, EPO (AT, BE, DE, DK, FR, GB, IT, NL, SE) Patent No. 472309. **Vehicle tracking adjustment**, GB Patent No. 2257670. **Loading/unloading of air suspended vehicles**, EPO (BE, DE, ES, FR, GB, IT, NL) appn. 92307639. **Axle lift**, GB appn. 9404557, PCT, EPO (AT, BE, CH+LI, DE, ES, FR, GB, GR, IE, IT, LU, MC, NL, PT, SE, AU, LA, NZ, US) appn. PCT/GB94/458.

© MERITOR H.V.S..



The high quality assurance management systems applied by MERITOR are endorsed with the awarding of ISO 9001, Lloyd's Register Quality Assurance.

"MERITOR" is a registered trade mark of MERITOR H.V.S. Ltd in Great Britain, No. 1405496 in Class 12.

Meritor HVS Limited
Commercial Vehicle Systems
Rackery Lane, Llay
Wrexham LL12 0PB
U.K.
Telephone: +44 (0)1978 852141
Fax: +44 (0)1978 856173

Meritor HVS (Mityr-Mory) S.A.
Commercial Vehicle Systems
Z.I. du Moulin à Vent
9 rue des Frères Lumière
77290 Mityr-Mory
France
Telephone: +33 (0)1 64.27.44.61
Fax: +33 (0)1 64.27.30.45

Meritor HVS (Verona) s.r.l.
Commercial Vehicle Systems
Via Monte Fiorino, 23
37057 San Giovanni Lupatoto
Verona
Italy
Telephone: +39 045 8750399
Fax: +39 045 8750640 / 8750513

Meritor HVS (Barcelona) S.A.
Commercial Vehicle Systems
Ctra. Granollers - Sabadell Km. 13,3
Poligono Argelagues
08185 Lliçà de Vall
Spain
Telephone: +34 (9)3 843 95 68
Fax: +34 (9)3 843 83 59

ArvinMeritor Inc.
World Headquarters
2135 West Maple Road
Troy, Michigan 48084
U.S.A.
Telephone: +1 248 435 1000

ArvinMeritor
Commercial Vehicle Aftermarket AG
Neugutstrasse 89
8600 Dübendorf
Switzerland
Telephone: +41 (0)1 824 8200
Fax: +41 (0)1 824 8264

ArvinMeritor
Commercial Vehicle Systems
Postbus 255
5700AG Helmond
Churchillaan 204A
5705BK Helmond
Holland
Telephone: +31 (0)492 535805
Fax: +31 (0)492 547175

ArvinMeritor South Africa
Commercial Vehicle Systems
Telephone: +27 (0) 83 602 1603

For further information contact

Meritor HVS Limited
Commercial Vehicle Systems
Rackery Lane, Llay
Wrexham LL12 0PB
U.K.
Telephone: +44 (0)1978 852141
Fax: +44 (0)1978 856173

www.arvinmeritor.com

© Copyright 2002
Meritor Automotive
All rights Reserved

Publication. 4.84.2

Descriptions and specifications were in effect at the time of publication and are subject to change without notice or liability. Meritor reserve the right to make design improvements, change or discontinue parts at any time.

ArvinMeritor™